



ULTF-C74i

BIOMEDICAL ULT FREEZER

The chest design is an economical choice, that preserves cold well due to the horizontal lid.



DIMENSIONS	
Outer Dimensions HxWxD, mm	921x550x550
Inner Dimensions HxWxD, mm	450x390x390
Weight Gross/Net, kg	74 / 50
Material inner cabinet	Painted Steel
Material outer cabinet	Painted Steel
Packaging weight, kg	24
Packaging dimensions HxWxD, mm	1008x705x795
Insulation thickness	80
Insulation type	Polyurethane with Cyclopentane
Mobility	Standard: 4 castors with brakes
Refrigerant, Type / gram	Nature R2 / 12l
Variable Speed Compressor	No
Internal Air Distribution	Static
Number of probes	1
CONTROLLER	
Controller	i-Care, Touch screen
Controller language	EN, DE, FR
USB Connection	Yes
Logging	Data, Alarms & Events
Temperature graph	Yes
High/Low temp. Alarm	Yes
Open door alarm	No
Probe failure alarm	Yes
Power failure alarm	Yes
STORAGE	
Volume, Gross/Net, L	74 / 7l
Cryobox "2 capacity	40
2 ml vials capacity	4.00
Inner lids	Yes
FEATURES	
Lock	Yes
LED light	No
Battery Backup for Controller, 24h	Yes
VIP (Vacuum Insulated Panel)	No
Door frame heater	No
Porthole	Yes - Ø 12,5 mm
Dry Contact	Yes
Vacuum valve	No
Door	Solid



ULTF-C74i

BIOMEDICAL ULT FREEZER

The chest design is an economical choice, that preserves cold well due to the horizontal lid.

Voltage/Frequency	Voltage/Hz	230V/50Hz
Max Ambient	°C	30°C
Max Humidity	% rh	65%
PERFORMANCE		
All data in RT20°C		
Temperature Range	°C	-20 to -86
Uniformity in performance - difference between top and bottom	°C	+/- 0,9
Pull down time	Minutes	72min to -75°C
Hold over time	Minutes	64 min to -60°C
Noise	dB	54
Energy Saving Mode	kWh/24h	4,018 kWh/24h Set -70
Energy Consumption, kWh / 24h	kWh/24h	5,325 kWh/24h Set -82
Energy year	kWh/year	1943,25 kWh/y Set -82°C
Instant Power Consumption	kW	PD 0,540-0,370/Stable 0,340
Heat Rejection	W	370
U-Value	W/m ² K	0,19
COOLING COMPONENTS		
Refrigerant/Amount (gram)		Nature R 2/121gr
Number of compressors	pcs	1
Variable speed compressor	Yes/No	No
Internal air distribution (type of)		Static
Evaporator Fan	Yes/No/Variable	No
Condenser Fan	Yes/No/Variable	Yes
Number of probes	pcs	1
Defrost	Yes/No	No



ULTF-C74i

BIOMEDICAL ULT FREEZER

The chest design is an economical choice, that preserves cold well due to the horizontal lid.

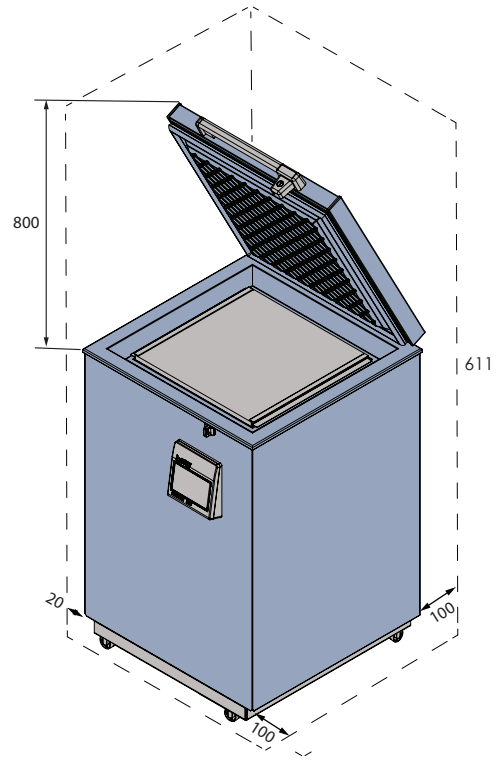
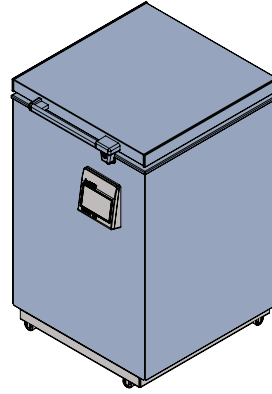
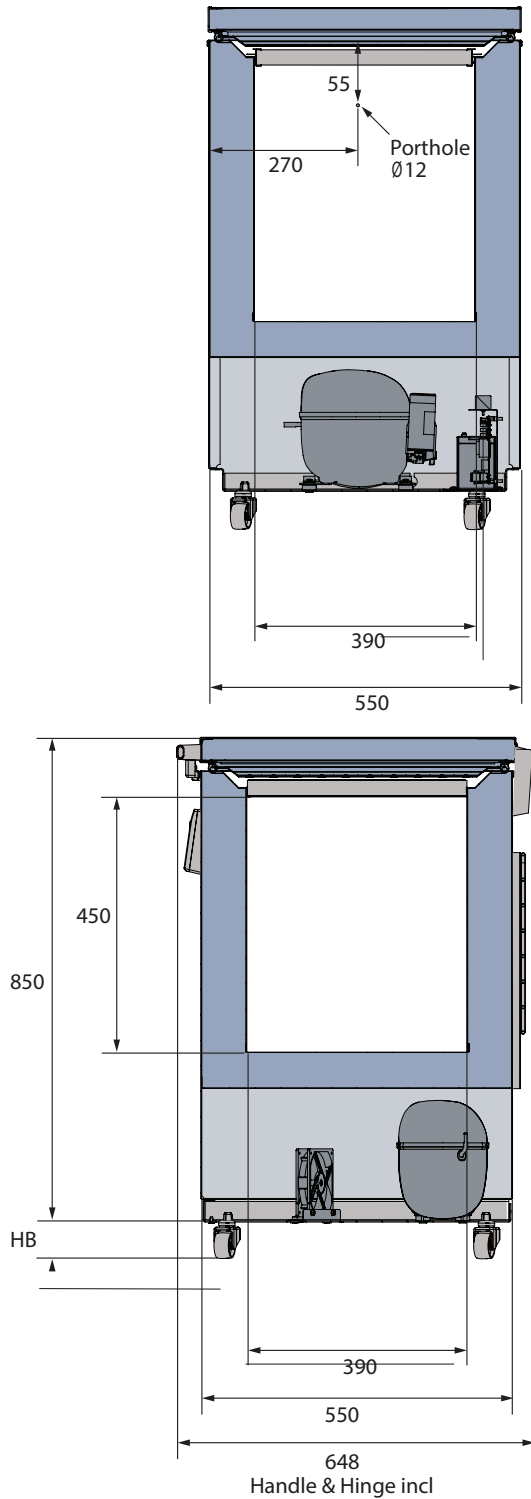

All measurements in mm.

HB: Height of base
(HB is adjustable when given value is xx-xx)

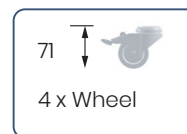



ULTF-C74i

BIOMEDICAL ULT FREEZER

The chest design is an economical choice, that preserves cold well due to the horizontal lid.

SENSOR POSITION

FRONT VIEW

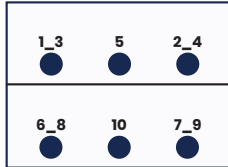

TOP VIEW

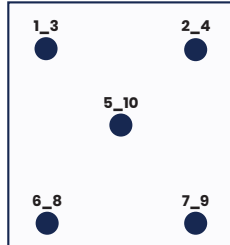

MODEL

ULTF-C74i

Test type	10-point test
Test environment	Controlled conditions, empty cabinet
Ambient temperature	20°C
Humidity	60%
Set-point	-82°C
Sensor used	25gr tinned brass formed as a cylinder with a diameter of 15,2 mm
Installation	Appliance installed according to instruction manual conditions
Refrigerant	Nature R 2

SENSOR TEMPERATURE

Sensor position	P1	P2	P3	P4	P5	P6	P7	P8	P9	P10
Max	-83,9	-85,3	-85,2	-84,9	-85,6	-85	-85	-84,5	-85	-84,6
Avg.	-84,5	-85,9	-85,8	-85,5	-86,2	-85,6	-85,5	-85	-85,6	-85,1
Min.	-85,1	-86,5	-86,2	-86,2	-86,9	-86,3	-86,3	-85,6	-86,3	-85,7

WARM UP & PULL DOWN

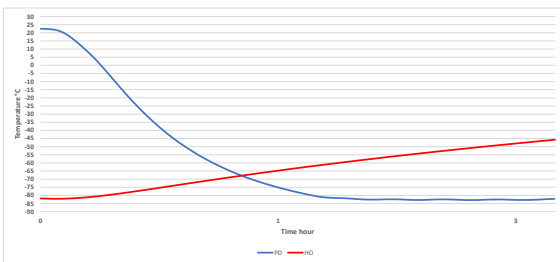

CYCLIC OPERATION

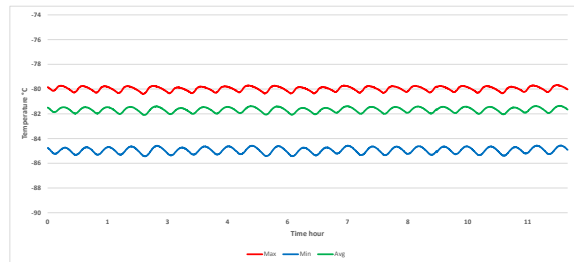

TYPICAL PERFORMANCE IN AMBIENT 20°C – EMPTY CABINET

Avg. cabinet temperature	-85,5°C
Peak variation from set-point	+/- 0,9°C
Stability in avg.	1,0°C
1 min. door open recovery to -75°C avg. temperature	6 min.
Cycle rate on/off	16 / 7 min.
Duty cycle	68%
Energy consumption - Normal mode	5,32 kWh/day
Energy consumption - Energy saving mode	4,01 kWh/day
Pull down time to -75°C avg. temperature	72 min.
Hold over time from -82°C to -60°C	64 min.
Heat rejection	370 W