



BIOMEDICAL

# ULTF-C296i

## CHEST ULT FREEZER

The chest design is an economical choice, that preserves cold well due to the horizontal lid.

-20°C  
-86°C



### DIMENSIONS

Outer Dimensions HxWxD, mm	831x1260x608
Inner Dimensions HxWxD, mm	624x1100x440
Weight Gross/Net, kg	100 / 78
Material inner cabinet	Painted Steel
Material outer cabinet	Painted Steel
Packaging weight, kg	22
Packaging dimensions HxWxD, mm	900x1313x725
Insulation thickness	80
Insulation type	Polyurethane with Cyclopentane
Mobility	Standard: 4 castors with brakes
Refrigerant, Type / gram	Nature R2 / 143
Variable Speed Compressor	No
Internal Air Distribution	Static
Number of probes	1

### CONTROLLER

Controller	i-Care, Touch screen
Controller language	EN, DE, FR
USB Connection	Yes
Logging	Data, Alarms & Events
Temperature graph	Yes
High/Low temp. Alarm	Yes
Open door alarm	No
Probe failure alarm	Yes
Power failure alarm	Yes

### STORAGE

Volume, Gross/Net, L	296 / 284
Cryobox "2 capacity	216
2 ml vials capacity	21.600
Inner lids	Yes

### FEATURES

Lock	Yes
LED light	No
Battery Backup for Controller, 24h	Yes
VIP (Vacuum Insulated Panel)	No
Perimeter Heater	No
Porthole	Yes - Ø 12,5 mm
Dry Contact	Yes
Vacuum valve	No
Door	Solid



# ULTF-C296i

## CHEST ULT FREEZER

The chest design is an economical choice, that preserves cold well due to the horizontal lid.

<b>Voltage/Frequency</b>	Voltage/Hz	230V/50Hz
<b>Max Ambient</b>	°C	25°C
<b>Max Humidity</b>	% rh	65%
<b>PERFORMANCE</b>		
<b>All data in RT20°C</b>		
<b>Temperature Range</b>	°C	-20 to -86
<b>Uniformity in performance - difference between top and bottom</b>	°C	+/- 1,2
<b>Pull down time</b>	Minutes	130 min to -75°C
<b>Hold over time</b>	Minutes	72 min to -60°C
<b>Noise</b>	dB	55
<b>Energy Saving Mode</b>	kWh/24h	7,041 kWh/24h Set -70
<b>Energy Consumption, kWh / 24h</b>	kWh/24h	9,855 kWh/24h Set -82
<b>Energy year</b>	kWh/year	3597,1 kWh/y Set -82°C
<b>Instant Power Consumption</b>	kW	PD 0,710-0,550/Stable 0,520
<b>Heat Rejection</b>	W	642
<b>U-Value</b>	W/m <sup>2</sup> K	0,2
<b>COOLING COMPONENTS</b>		
<b>Refrigerant/Amount (gram)</b>		Nature R 2/143gr
<b>Number of compressors</b>	pcs	1
<b>Variable speed compressor</b>	Yes/No	No
<b>Internal air distribution (type of)</b>		Static
<b>Evaporator Fan</b>	Yes/No/Variable	No
<b>Condenser Fan</b>	Yes/No/Variable	Yes
<b>Number of probes</b>	pcs	1
<b>Defrost</b>	Yes/No	No



# ULTF-C296i

## CHEST ULT FREEZER

The chest design is an economical choice, that preserves cold well due to the horizontal lid.

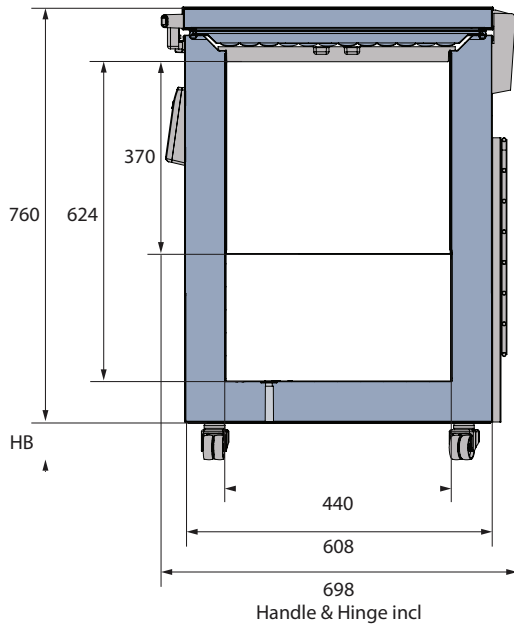
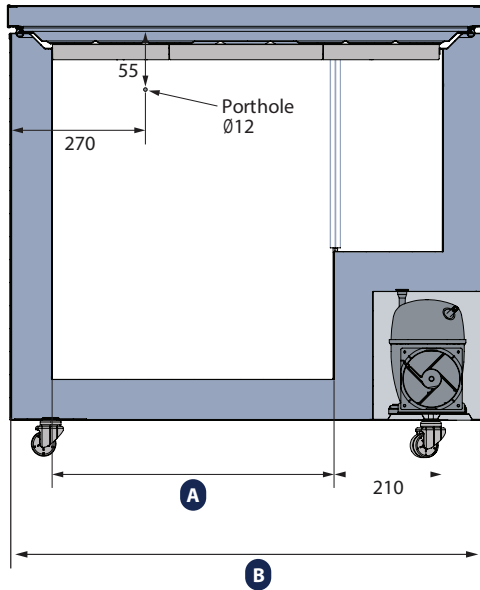
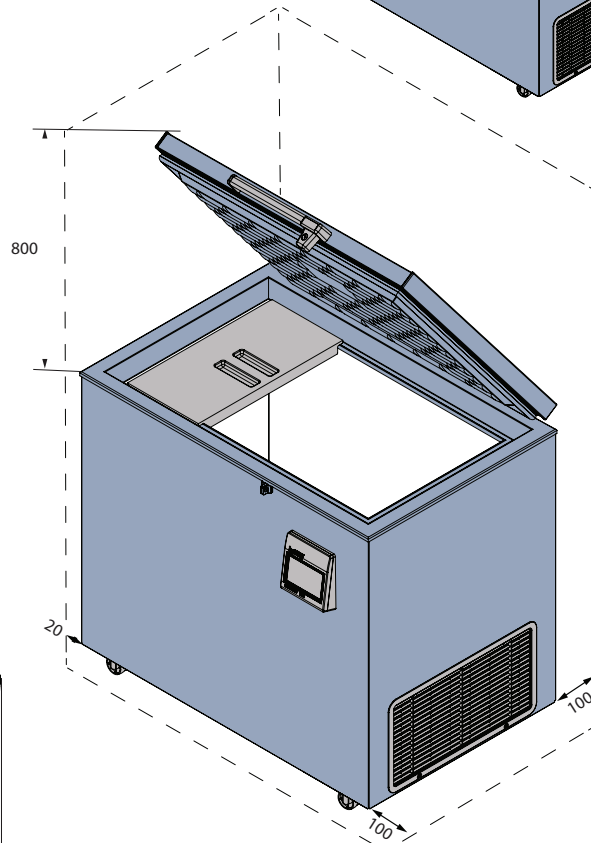
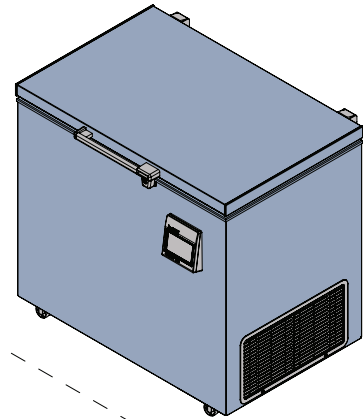

MODEL	A	B
ULTF-C198i	550	920
ULTF-C296i	890	1260
ULTF-C383i	1190	1560

All measurements in mm.

HB: Height of base  
(HB is adjustable when given value is xx-xx)

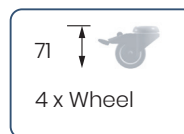



# ULTF-C296i

## CHEST ULT FREEZER

The chest design is an economical choice, that preserves cold well due to the horizontal lid.

### SENSOR POSITION

FRONT VIEW

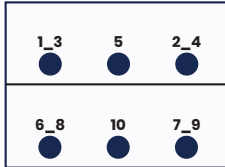

TOP VIEW

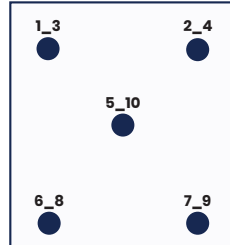

### MODEL

### ULTF-C296I

Test type	10-point test
Test environment	Controlled conditions, empty cabinet
Ambient temperature	20°C
Humidity	60%
Set-point	-82°C
Sensor used	25gr tinned brass formed as a cylinder with a diameter of 15,2 mm
Installation	Appliance installed according to instruction manual conditions
Refrigerant	Nature R 2

### SENSOR TEMPERATURE

Sensor position	P1	P2	P3	P4	P5	P6	P7	P8	P9	P10
Max	-81,5	-82,7	-82,9	-82,3	-82,1	-80,7	-81,6	-80,9	-82	-81,3
Avg.	-82,4	-83,5	-83,8	-83,2	-82,7	-81,4	-82,2	-81,5	-82,7	-82,1
Min.	-83,3	-84,5	-84,7	-84,2	-83,5	-82,1	-82,9	-82,3	-83,6	-83

### WARM UP & PULL DOWN

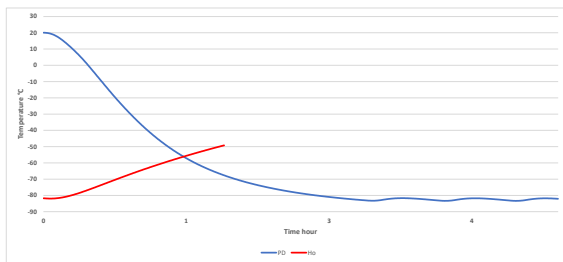

### CYCLIC OPERATION

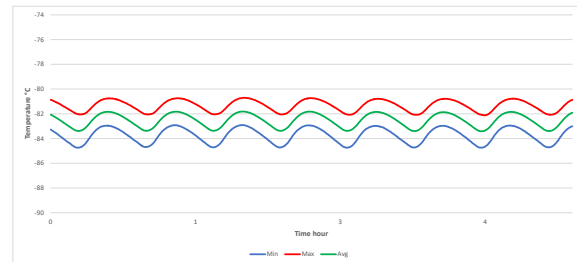

### TYPICAL PERFORMANCE IN AMBIENT 20°C – EMPTY CABINET

Avg. cabinet temperature	-82,5°C
Peak variation from set-point	+/- 1,2°C
Stability in avg.	0,8°C
1 min. door open recovery to -75°C avg. temperature	<1 min.
Cycle rate on/off	30 / 7 min.
Duty cycle	77,3%
Energy consumption - Normal mode	9,85 kWh/day
Energy consumption - Energy saving mode	7,04 kWh/day
Pull down time to -75°C avg. temperature	130 min.
Hold over time from -82°C to -60°C	72 min.
Heat rejection	642 W